

# Hillmar

Hillmar Industries Ltd.

7371 Vantage Way  
Delta, BC V4G 1C9  
P:604 946-7115 F:604 946-0329  
info@hillmar.com www.hillmar.com

## CABLE REEL VD DAVD GBSR DAVD-1500-GB90DD-15KV-560 SPECIFICATION SHEET SLS & MKTG ENGLISH

Sheet Number:

Job Number:

Form Number:  
629-864-75976PT

Company / Project Reference:

Date.:

Page.:

Document Package No.: Rev.:

Inventor Drawing

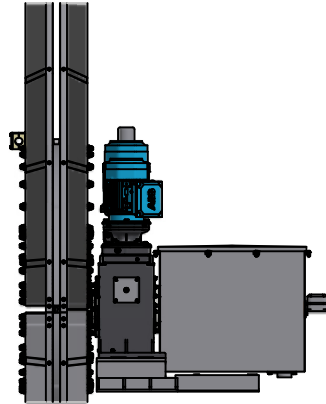

FEATURE	CODE
Drive Assy Vector Drive	DAVD
Vector Drive Motor Size	1500
Gearbox Dual Drive	GB90DD
Voltage	15KV
Fiber Optic	Not available
Vector Drive Torque Nm	560

<b>Example for ordering</b>	DAVD-1500-GB90DD-15KV-560
-----------------------------	---------------------------

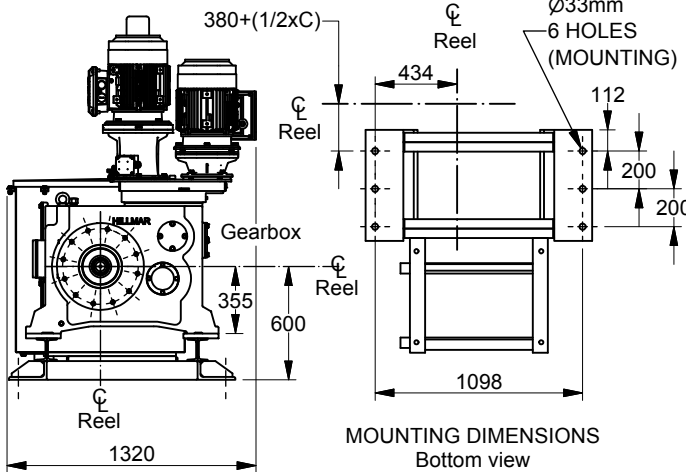

### TECHNICAL DATA

Motor Size	15 kW
Spool Sizes Available	6.5m to 8.5m
Gearbox Hollow Shaft	95mm
Gearbox Drive Torque Nm	20000
Gearbox Max Overhang Load	100kN
Slipring Enclosure Design	15kV
Rotary Switch Ratio	RS
Drive Weight Excluding Spool	1310kg
Spool Weight	Contract Specific
Mounting Holes	6 x Ø33
Mounting Bolts	6x M30 GR10.9
Slipring Enclosure	SS304

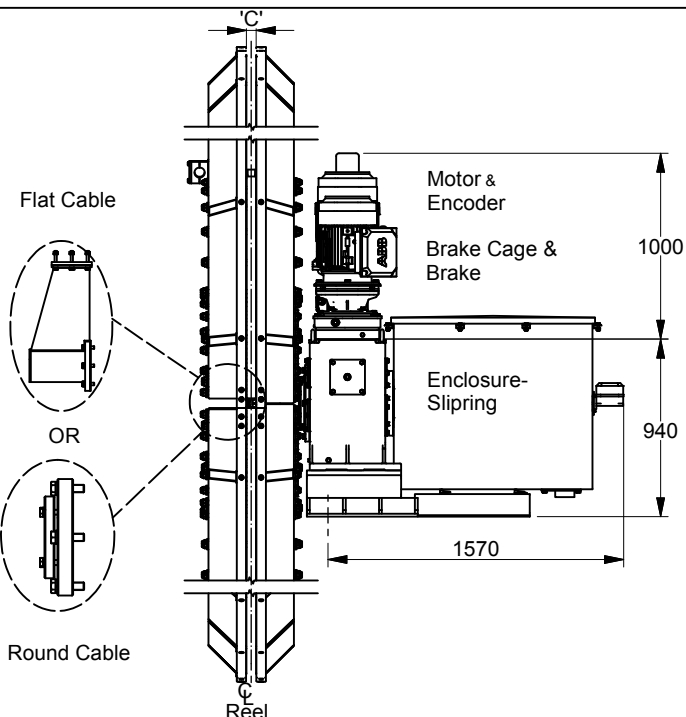

### NOTES

For Other Reel Types refer to one of the following sections:

Flat Cable Reel

Hose Reel

Control Reel

Vector drive Reel

Document Template #710-101-62058

\*\* ALL TECHNICAL DATA IS SUBJECT TO CHANGE WITHOUT NOTICE \*\*

Hillmar works have a fully registered ISO 9001-2008 quality assurance programme (QCB #01-1525)